



## WHEN SIZE DOES MATTER...!

Zeel Design is an engineering consulting firm and manufacturer of specialized parts and vehicles that specializes in styling, engineering, CAD, FEA, manufacturing, CNC machining, binding and welding.

Since the company designs and manufactures parts and accessories for several manufacturers that have no access to 3D drawings, it needed a powerful reverse engineering tool that would enable it to reduce the production time of CAD drawings.

### AN INVESTMENT THAT FAST TRACKED THE COMPANY

Creaform's Handyscan 3D self-positioning handheld laser scanning technology was familiar to Zeel Design. Indeed, both companies were already doing business together, as Creaform's 3D scanning experts had carried out a few 3D files generation projects in the past for Zeel Design. Seeing how easy to use the Handyscan 3D scanners were, and how quickly the data acquisition and post-treatment processes were done, Zeel Design came to the conclusion that it would be profitable to invest in an EXAscan laser scanner. In doing so, the engineering consulting firm **managed to reduce by 70-90% the time spent previously on CAD drawings and reverse engineering process.**

Overall, the company uses its Handyscan 3D scanner to scan existing compo-



nents and create 3D images of them to design parts and accessories based on space constraints.

### A CUSTOMIZED HARLEY-DAVIDSON

More particularly, the scanner was used for a bike overhauling project where the client, owner of a brand new Harley-Davidson of the latest model, wished to

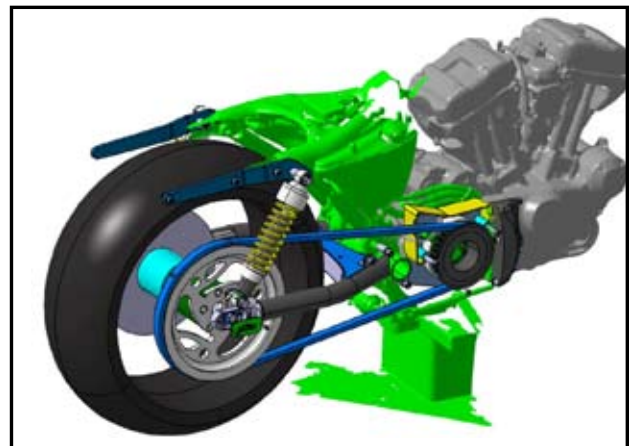

fit his rear wheel with a larger tire. For that, a wide tire converter kit needed to be designed and built.

The first step for the Zeel Design team was to partially take off the bike's back end to access the components that needed scanning. Then, they coated the chassis, the engine and rear arm mounting areas as well as some parts of the back end with non destructive paint before scanning all components and assembly — all of that, in the shop.

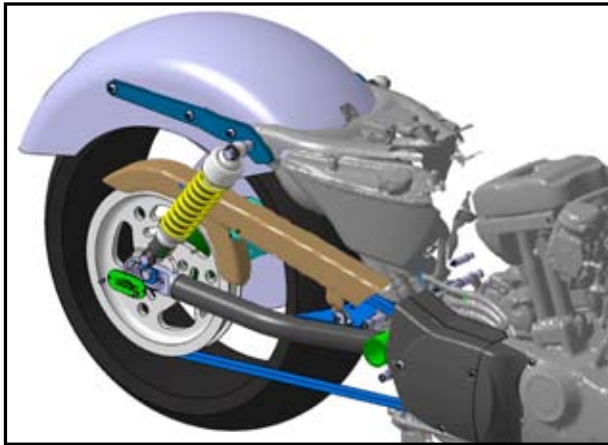

Since no complete 3D surface drawings of the parts were needed, the team could use the scanner to get the points of reference they needed to design the new components for the wide tire converter kit.

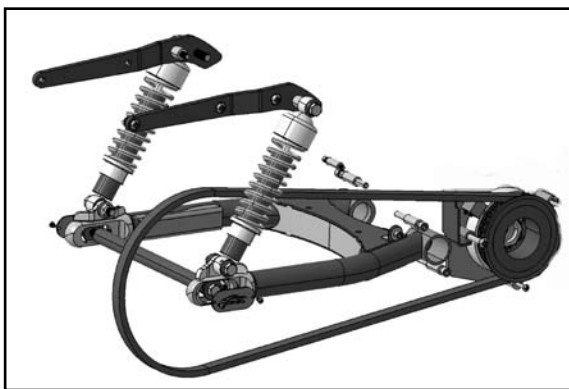

**WHEN YOU ACE IT WITH 10%...WORKING 1 HOUR RATHER THAN 10!**

Thanks to its ease of use and data acquisition speed, the Handyscan 3D self-positioning handheld laser scanner played a key role in drastically reducing the project turnaround times. A bike chassis

is very complex and presents irregular 3D shapes; therefore, the conventional methods used for designing modified components are long and tedious. Conversely, 3D scanning makes it possible to get a high accuracy 3D picture of the assembly and all the components at the same time, without having to draw them in 3D. End result: the use of the Handyscan 3D scanner now enables Zeel Design to execute in roughly 1 hour tasks that previously required more than 10 hours to do!

### A SATISFIED CLIENT

According to Michael Zeel, president of Zeel Design, "Considering how often we use our EXAscan, and if we add up the working hours that we are saving, we expect to get excellent ROI very quickly. I'm very pleased with the technology, and I do recommend it to other companies from the vehicles and parts manufacturing business."



Zeel Design Inc. [www.zeeldesign.com](http://www.zeeldesign.com)